

# Grounding Accessories 3000 Series Instruction Sheet



## Your choice of four kits to meet almost any grounding need

In any area where static-sensitive electronic components or boards are handled, proper static protection is essential. A variety of static control devices is available to meet the requirements necessary to protect both the electronics and the people handling them. But these devices require proper grounding to perform their functions. These four kits cover a variety of possible uses, from single-point grounding to multiple points connected to a common ground. They meet the technical requirements of ANSI/ESD S6.1 - Grounding.

### 3048 Wrist Strap/Table Mat Grounding System

Two wrist straps can be connected to the Wrist Strap/ Table Mat Grounding System. The 15 foot (4.6 m) ground cord is connected directly to hard ground. Snapping the Grounding System to either of the two connectors in the corners of the table mat provides reliable, common point grounding for the wrist straps and the table mat simultaneously.

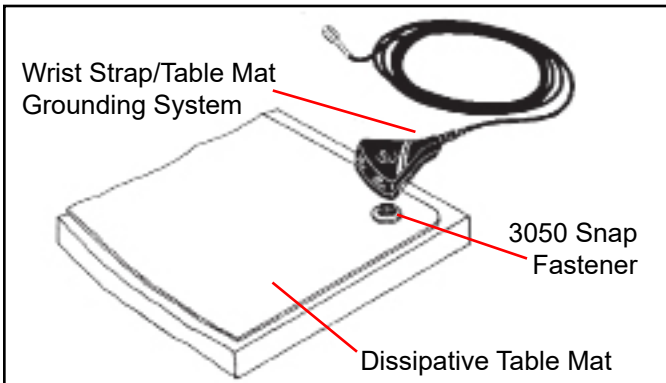

Figure 1. 3048 Wrist Strap/Table Mat Grounding System.

### 3047 Common Point Grounding System

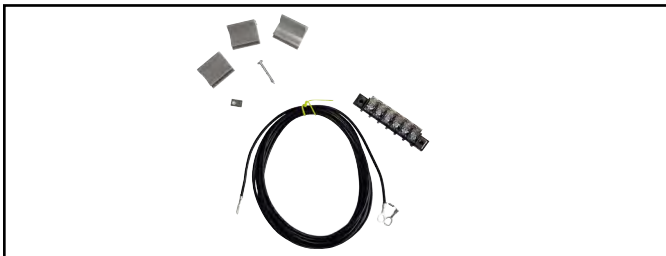

Figure 2. 3047 Common Point Grounding System.

To provide true common point grounding for all workstation components, the kit 3047 offers a single-row, six-terminal strip. No additional components offering resistance are in the path on any link of the static protection system. Hard grounds are available on the six terminals. The system is easily accessible, and mounts on any flat surface in new or existing workstation environments. The protective cover is connected to ground via a one-megohm resistor for the maximum in personnel safety. In addition, three cable clips are included to aid you in ground cord management.

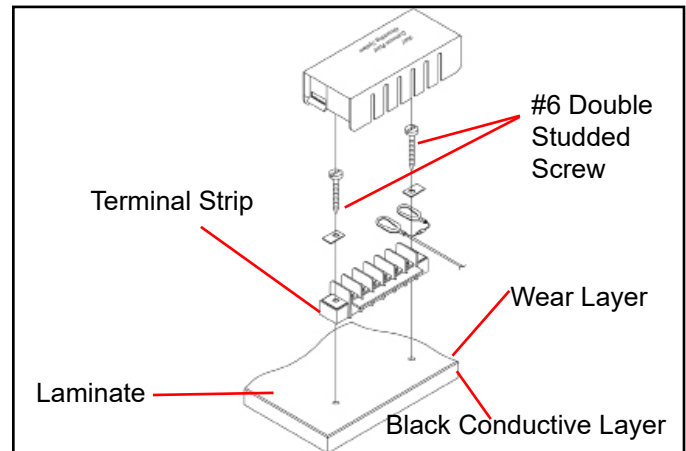

Figure 3. Installing the 3047 Common Point Grounding System (top).

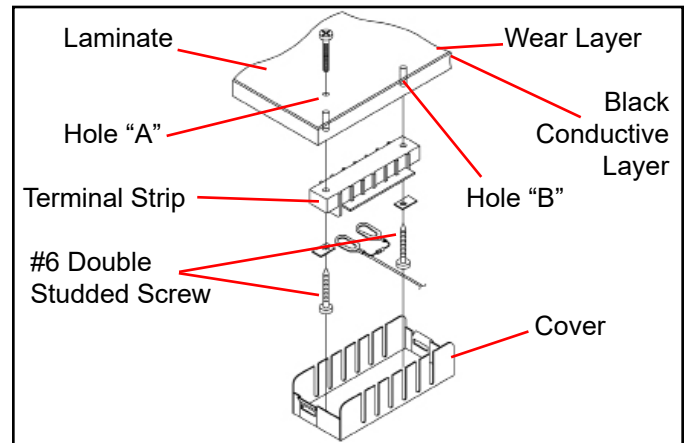

Figure 4. Installing the 3047 Common Point Grounding System (bottom).

## 3042 Wrist Strap Grounding System



Figure 5.3042 Wrist Strap Grounding System.

Grounding of two wrist straps using a common point to ground is possible with the system 3042. It is easy to identify for this purpose, with a clearly visible ground symbol. Compact in size, it mounts to any flat surface where a wrist strap needs to be connected to a reliable ground. The kit may be mounted on new workstations or retrofitted onto any existing workstation. Components of the kit include one static dissipative engineering grade plastic housing, one 10-foot (3 m) grounding cord with multi stud ring terminal, strain relief for the grounding cord, two banana jacks built into the housing, and two #8 galvanized, self-tapping Phillips screws.

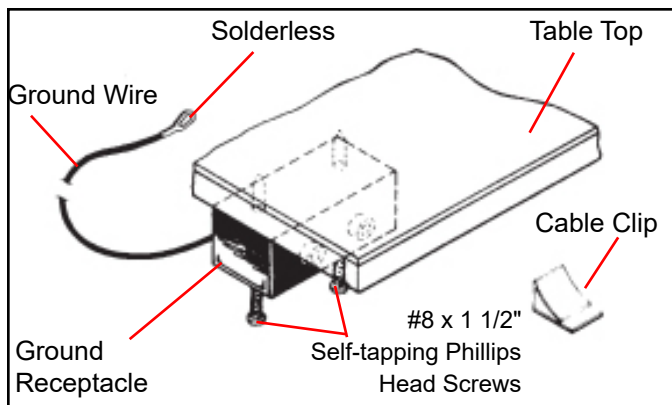

Figure 6. Installing 3042 Wrist Strap Grounding System.

## 3044 Laminate Grounding System

To properly ground a workstation with Static Protective Hard Laminate, this kit gives you a choice of four methods to provide proper grounding. This can be accomplished from the top or the bottom of the work surface. Contents of the kit include the hardware needed to establish reliable connections to ground.



Figure 7. 3044 Laminate Grounding System.

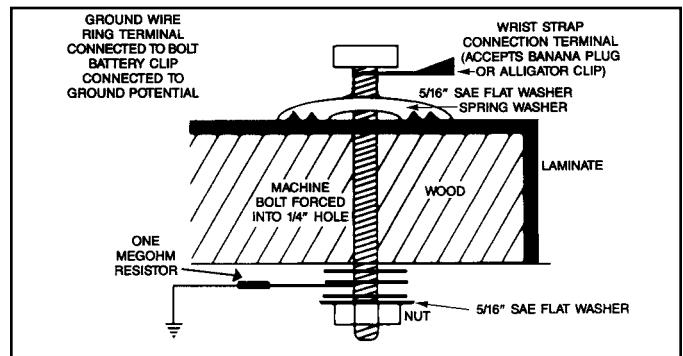

Figure 8. Installation of the 3044 Laminate Grounding System.

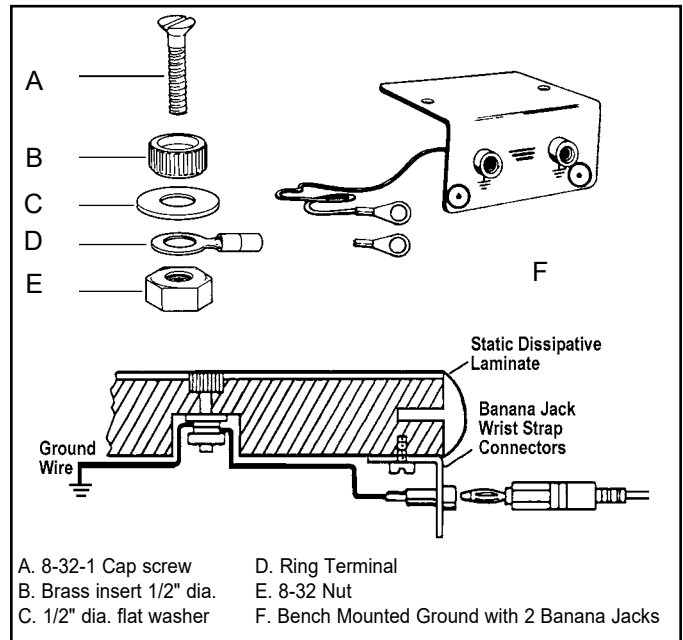

Figure 9. Component Parts and Installation of the Flush Mount Inserts and the Flush Mount Laminate Ground Insert.

### Important Notice

Before using this product, you must evaluate it and determine if it is suitable for your intended application. You assume all risks and liability associated with such use.

### Limited Warranty, Warranty Exclusions, Limit of Liability and RMA Request Instructions

See the SCS Warranty - [StaticControl.com/Limited-Warranty.aspx](http://StaticControl.com/Limited-Warranty.aspx)